

Quick Network Block QNB-1

Connections made simple backed up by helpful diagnostics ...

The Actisense® Quick Network Block (QNB-1) allows backbone networking connections to be made easy and fault-free on National Marine Electronics Association (NMEA) buses and networks.

The QNB-1 is two products in one, being compatible with both NMEA 0183 buses and NMEA 2000 networks.

When used on an NMEA 0183 bus, the QNB-1 provides an easy junction box to connect multiple NMEA 0183 devices together. A talker device is connected to one of the network connection points, while each listener is connected to the remaining connection points.

Secondly, it is a multi-drop NMEA 2000 network backbone connection block, adhering to the barrier strip connection type detailed in the NMEA 2000 specification documents.

To protect the power hookup, a fused connection is provided to the network backbone.

This allows the current to be limited to the safe level for the network. Two fuses are provided, each powering two halves of the QNB-1, meaning that if the fuse blows to one half of the system, the other half can remain powered.

In the simplest configuration, the QNB-1 can also be used as a simple fused IP66 sealed power connection block.

LED indicators show power status, detect power reversal, and show whether the fuses are still intact.

In addition, detector circuitry is provided to indicate the presence of data on the connected bus or network.

No software or setup is required.

The installation manual provided with the QNB-1 provides example connection diagrams to aid the user with setting up their network.

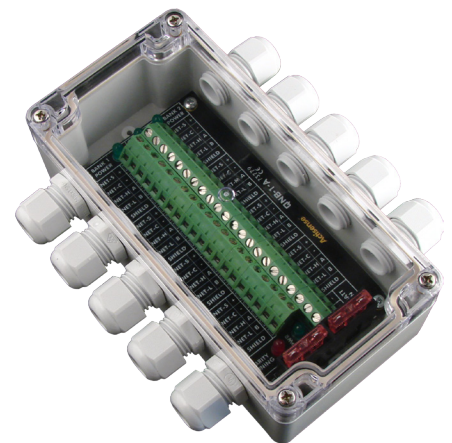

NMEA 2000 use

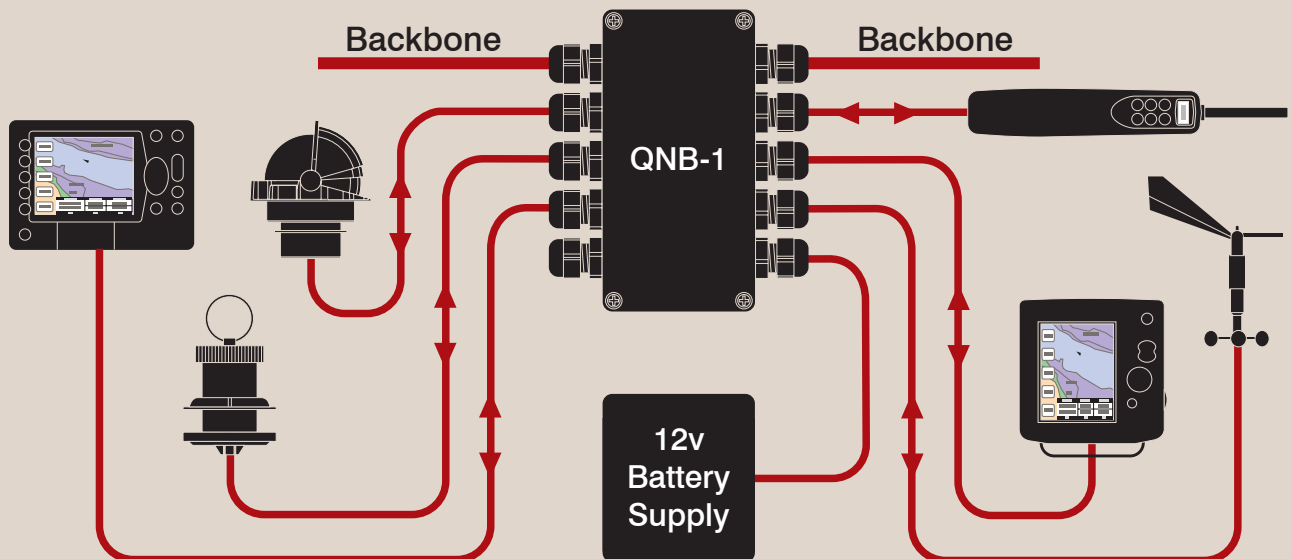

Quick Network Block QNB-1

Specifications

Connections

- High quality rising cage clamp connectors rated at 16A
- 16 Amp Rated (2 x 4 = 8 Amps of fusing supplied as standard)
- Wire size range 26 to 12 AWG (0.2-2.5mm²)
- Eight x 5 way connection points provided, allowing up to six NMEA 2000 network drops and two backbone connections, or in an NMEA 0183 system, it allows one talker to talk to seven other listeners.

Overcurrent

- Fuses limit current in each leg to provide short circuit protection - 4 Amp fuses supplied as standard for compatibility with NMEA 2000 micro backbone wiring specification.

Data Latency

- None

Detector circuits

- Supply Voltage range: 10 to 35 volts DC
- Power Consumption: 10 mA @ 12v DC / 120mW
- Compatible with all baud rates from 4800 (NMEA 0183 to 250 kBaud (CAN/ NMEA 2000)

Environmental

- Recommended operating temperature: -20°C to +70°C
- Sealed case and grommets provide IP66 protection

General

- Weight: 500 grams
- Dimensions: see diagram right
- Guarantee: 2 years

Built-in Firmware / Software

- No Software required

Part number

- QNB-1

Dimensions

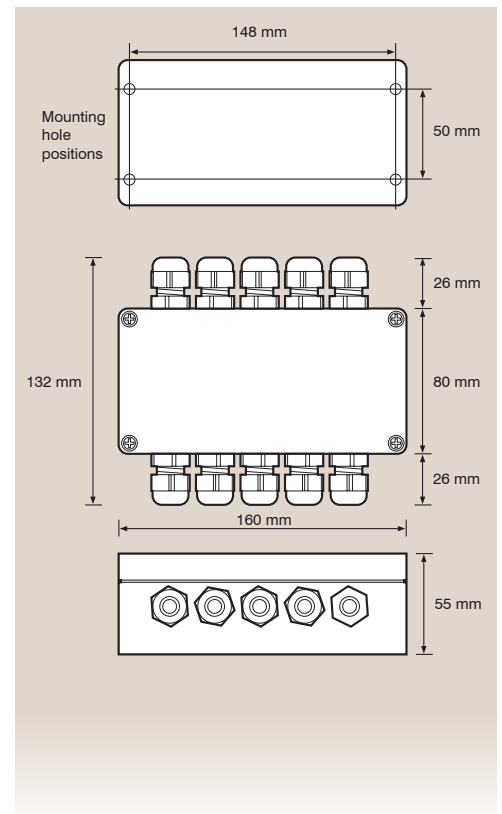

Active Research Limited
 Unit 5, Wessex Trade Centre
 Ringwood Road, Poole
 Dorset UK BH12 3PF

t: +44 (0)1202 746682
 f: +44 (0)1202 746683
 e: sales@actisense.com
www.actisense.com

Actisense[®]

Actisense from Active Research